

TNO innovation
for life



DECHEMA



vito



DVGW



› **TRILATERAL INFRASTRUCTURE PROJECT
PHASE 0**

FINAL REPORT APRIL 2020

› CONTENT

- **MOTIVATION & CHALLENGES**
- **RESEARCH FINDINGS**
- **OUR COMBINED STRENGTH**
- **APPENDIX**

CONTACTS

Vito EnergyVille:	Frank Meinke-Hubeny Frank.Meinke-Hubeny@vito.be
DVGW:	Johannes Ruf ruf@dvgw-ebi.de
DECHEMA:	Florian Ausfelder Florian.Ausfelder@dechema.de
TNO:	Martijn de Graaff Martijn.deGraaff@tno.nl

PROJECT PARTNERS



"Science and Industry in Dialogue"

- Primary industry sector in the energy transformation
- Future feedstocks for the chemical industry
- Sustainable processes
- Industrial symbiosis



- Independent research facility in Karlsruhe, Germany
- Supports its member companies on their energy transition pathways with a focus on integrated gas infrastructure and gas technology
- Inspects and certifies gas appliances and is involved in national international standardization



"Vision on Technology for a better World"

- Research in cleantech and sustainable development
- Economic, technological and behavioural aspects of the current and future energy system
- Energy efficiency, renewable energy and flexibility



"We connect people and knowledge for innovation"

- Independent research organisation, VoltaChem program & Community
- Development of technology and knowledge
- Active in renewable feedstock, fuels, chemicals, CCUS and energy storage

› MOTIVATION & CHALLENGES

Motivation. Industrial energy consumption of industrial sites is enormous and defossilization is a challenge.

In this study, ammonia production serves as an example to discuss possible routes to CO₂-neutrality.

Highly interconnected industrial sites motivates for cross-border collaboration and infrastructure use.

Process transformation. For today's investment decisions only (on- and offsite) SMR-CCS is a technical feasible option considering a combination with step-by-step ramp-up of on-site electrolysis (PPA + grid electricity).

CO₂ cost reflection in final product cost is key information to derive individual transformation pathway.

Infrastructure transformation. Aiming for greenhouse gas neutrality requires new infrastructure or repurposing of existing ones.

Natural gas infrastructure assets can play a key role in future energy and feedstock supply for industrial sites given their high capacities and great availability.

Limitations. Possible transformation pathways remain unclear and are limited considering the required uninterruptible energy and feedstock supply.

Harmonization of national regulatory frameworks and legislation mandatory for intensifying of cross-border collaboration.

THE ARRA CLUSTER IS POPULATED BY MANY CHEMICAL COMPANIES IN DIFFERENT COUNTRIES BUT FACING THE SAME CHALLENGE OF COMPETITIVE DECARBONIZATION

- › What is needed to make the chemical industry climate-neutral?
 - › Large amounts of reliable process heat required (mostly steam, currently based on fossil fuels)
 - Alternative, renewable fuels to generate process heat biomass, **hydrogen, electricity**
 - › Chemical feedstock based on oil and natural gas
 - Recycling of plastics/chemicals, biomass, **CCU/PtX** ($\text{CO}_2 + \text{H}_2$)
 - › GHG emissions from fuel and processes
 - Replace fuels, capture (CO_2) process emissions → **CCS/CCU**, catalytic decomposition (N_2O)

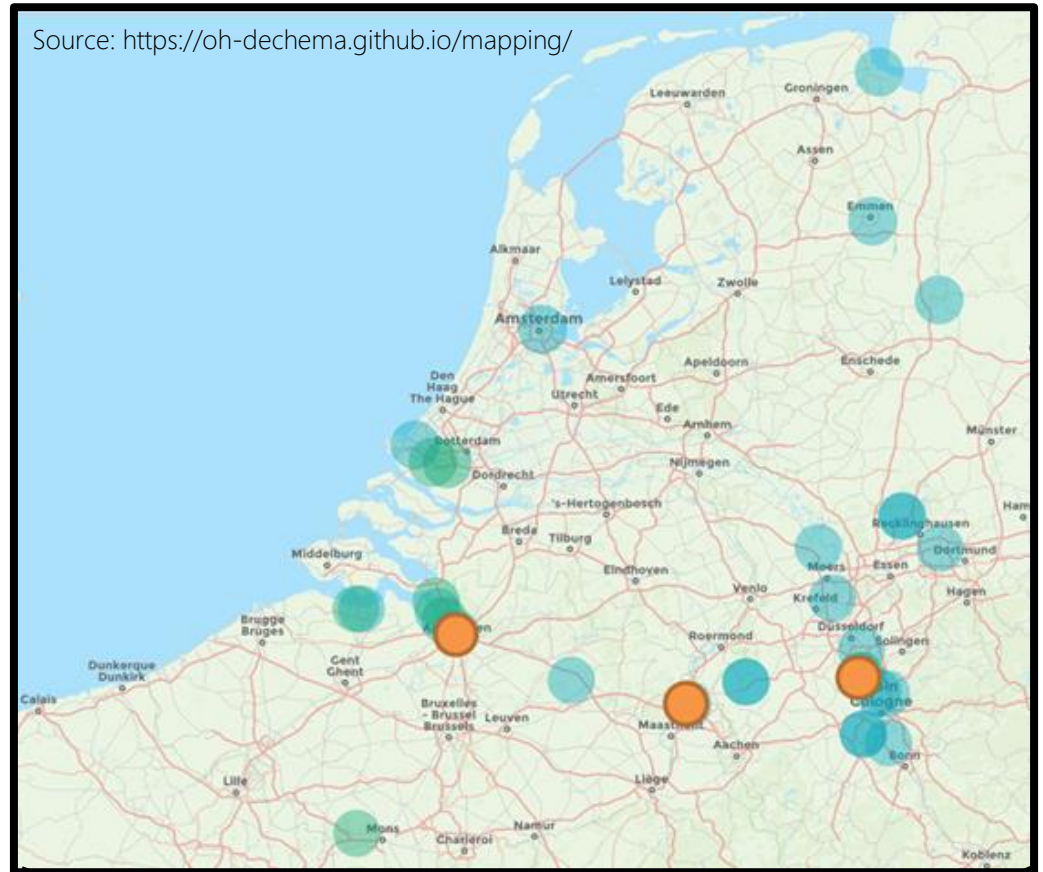

PRODUCTION IN ALL THREE COUNTRIES AND SUPPOSED EASE OF DECARBONIZATION MAKES AMMONIA WELL SUITED FOR A CASE STUDY

Ammonia

- › Main chemical products
- › Produced in all three countries
- › Has a significant natural gas demand (0.5- 1.0 % of national natural gas consumption)
- › Easy molecule to decarbonize

Main research questions:

- › What are the competitive decarbonization pathways?
- › What are the implications for the infrastructure the industrial site needs to be supplied with?
- › Which role can cross-border infrastructure play in the different scenarios?

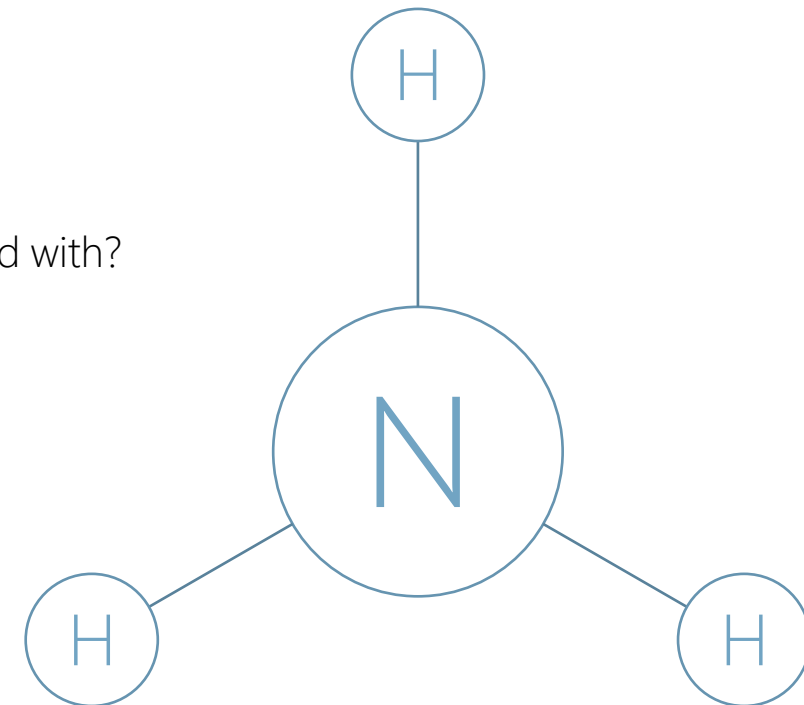

THREE SITES IN A 185 KM RADIUS PRODUCE ~20% OF EUROPE'S AMMONIA USING REFORMING OF NATURAL GAS

★ BASF ANTWERP, BE

- › Depreciated SMR plant
- › Annual ammonia production
~600 kton/annum (2017)
- › 38% of national natural gas non-energy use

★ CHEMELOT SITE GELEEN, NL

- › Depreciated SMR plant
- › Annual ammonia production
~1100 kton/annum (2017)
- › Annual urea production
~480 kton/annum (2017)
- › 28% of national natural gas non-energy use

★ CHEMPARK DORMAGEN, DORMAGEN, DE

- › Depreciated SMR plant
- › Annual ammonia production
~285 kton/annum (2017)
- › 6% of national natural gas non-energy use



4 CARBON-NEUTRAL PATHWAY SCENARIOS EXIST FOR SMR (BASED AMMONIA PRODUCTION (BUSINESS AS USUAL))

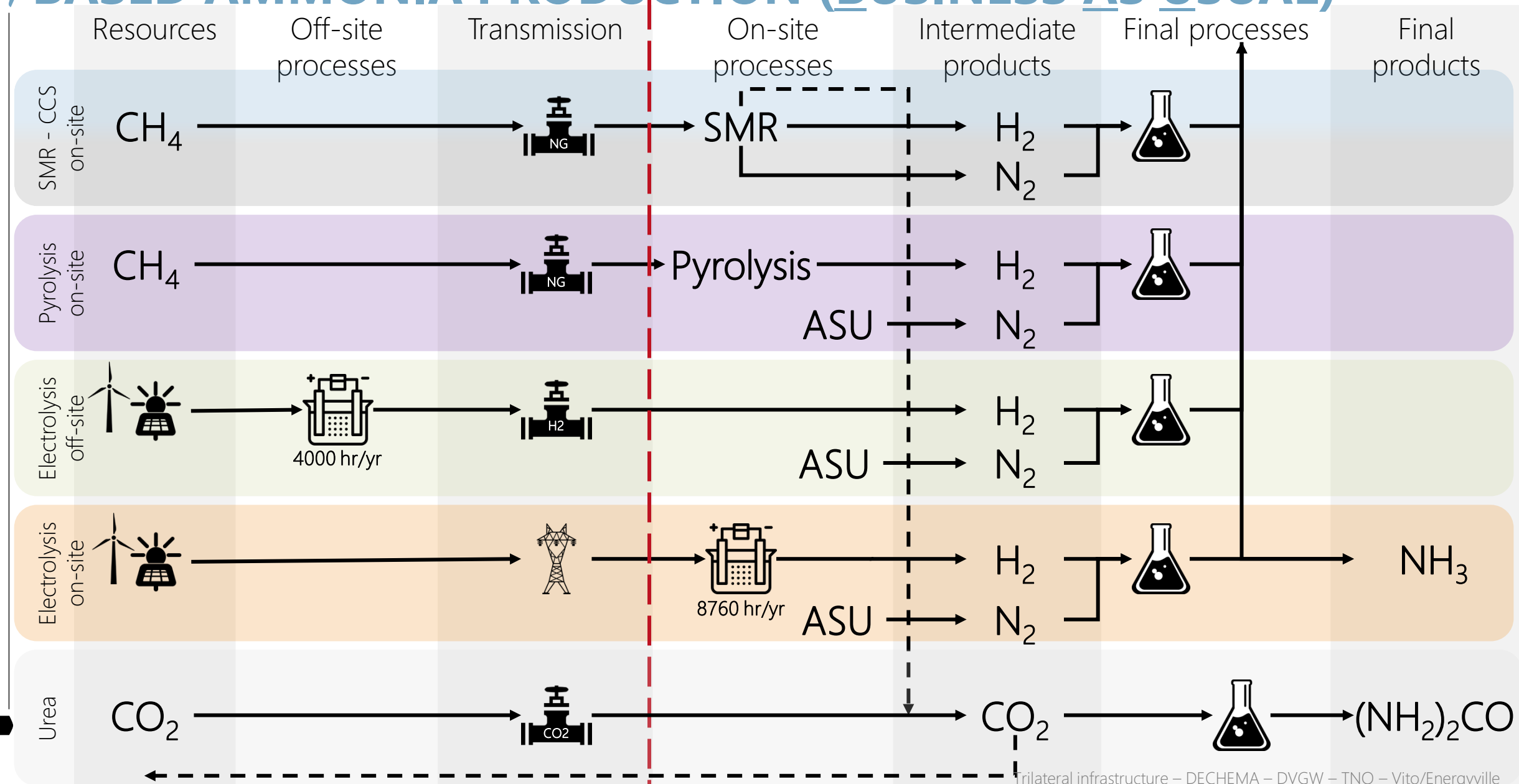

4 CARBON-NEUTRAL PATHWAY SCENARIOS EXIST FOR SMR BASED AMMONIA PRODUCTION (BUSINESS AS USUAL)

SMR - CCS
on-site

Natural gas is supplied by pipeline to the site, from which H_2 and N_2 is produced using Steam Methane Reforming (SMR); CO_2 that is produced can either be used in urea production, emitted into the atmosphere (grey H_2) or transported by pipeline and stored off-site (blue H_2)

Pyrolysis
on-site

Natural gas is supplied by pipeline to the site, from which H_2 is produced using methane pyrolysis; N_2 needs to be produced using an air separation unit (ASU) using grid electricity

Electrolysis
off-site

H_2 gas is produced from water electrolysis using **green electricity** (4000 full load hr/yr with storage) and transported to the site by pipeline; N_2 needs to be produced using an air separation unit (ASU) using grid electricity

Electrolysis
on-site

Grid electricity is supplied to the site, where it is used in water electrolysis (8760 full load hr/yr) to produce green H_2 ; N_2 needs to be produced using an air separation unit (ASU) using grid electricity

Urea

Synthesis of urea requires ammonia and carbon dioxide; when applicable, the CO_2 can be supplied from the SMR process, otherwise the CO_2 needs to be delivered to the site

MODEL: EVOLUTION OF KEY DRIVERS & PROJECTION ASSUMPTIONS

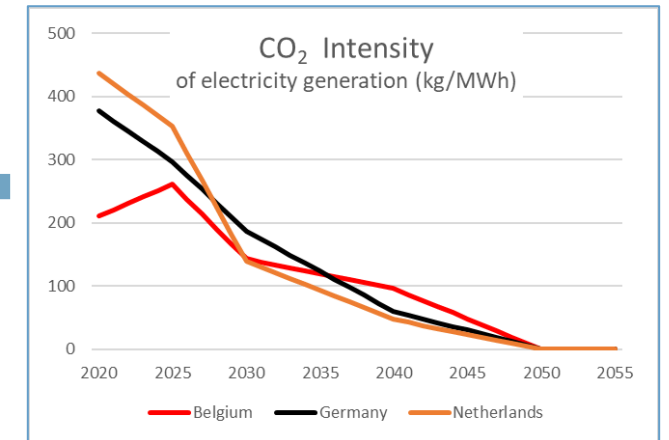
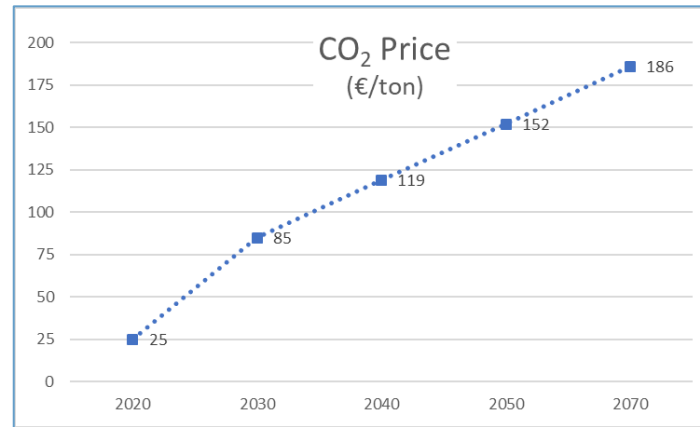
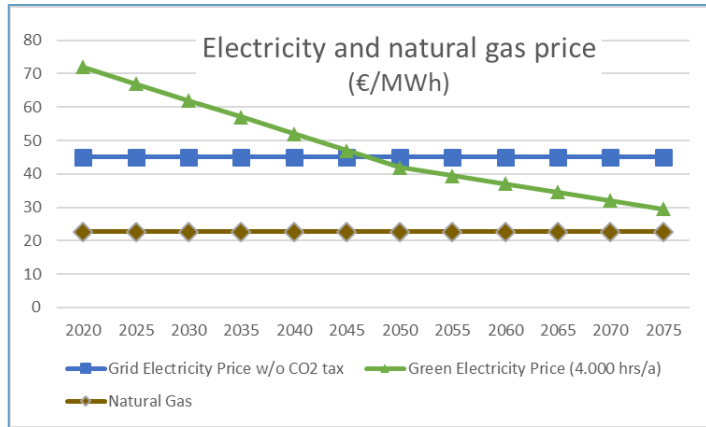

Improvements of installations:
CAPEX, OPEX, efficiency, ...

SMR
Pyrolysis
ASU

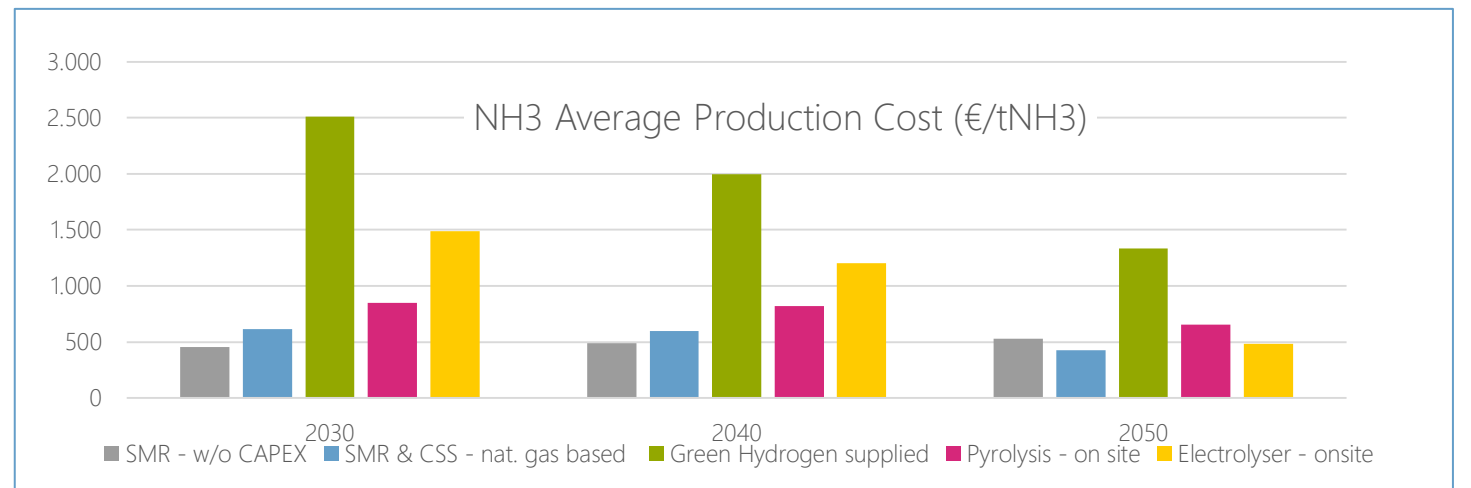

ALL PATHWAYS PROVIDE NET CARBON REDUCTION SOMEWHERE BETWEEN TODAY AND 2035..

- › .. But for today's investment decisions only SMR-CCS is a technical feasible option considering a combination with step-by-step ramp-up of on-site electrolysis (PPA + grid electricity)
- › On-site electrolysis becomes an option when CO₂-footprint of grid electricity drops below a certain value
- › Once methane pyrolysis becomes commercially available it offers lower CO₂ abatement cost than SMR-CCS
- › Limitations: Please note: large uncertainties due to low TRL (pyrolysis) and unknown CO₂-storage costs (blue hydrogen)

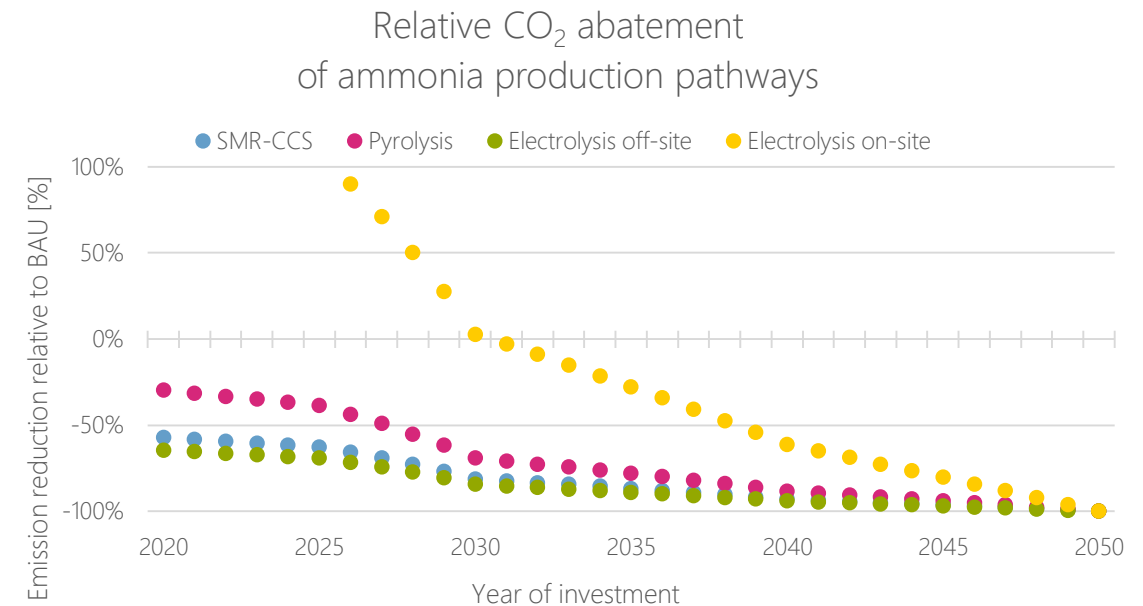

› IN TERMS OF ENERGY INFRASTRUCTURE CAPACITY, CHEMELOT SEEMS EQUIPPED FOR NO PATHWAY TODAY..

- › Impact on CO₂
 - › On-site SMR-CCS requires a **CO₂ pipeline** with a capacity of roughly **1.3 Mton/a**
 - › All other pathways lead to negative emissions and requires **0.35 Mton/a CO₂ transport** to the site as feedstock for urea
- › Impact on energy carriers
 - › Pyrolysis requires increase of **natural gas transport capacity** up to **81 PJ/a** (+6.4%** of Dutch national gas consumption)
 - › Electrolysis off-site requires a **hydrogen pipeline** with a capacity of **185 kton/a** (in scope of Gasunie's hydrogen backbone)
 - › Electrolysis on-site would require a **11 TWh/a power connection** (+20%** Dutch industrial electricity consumption)

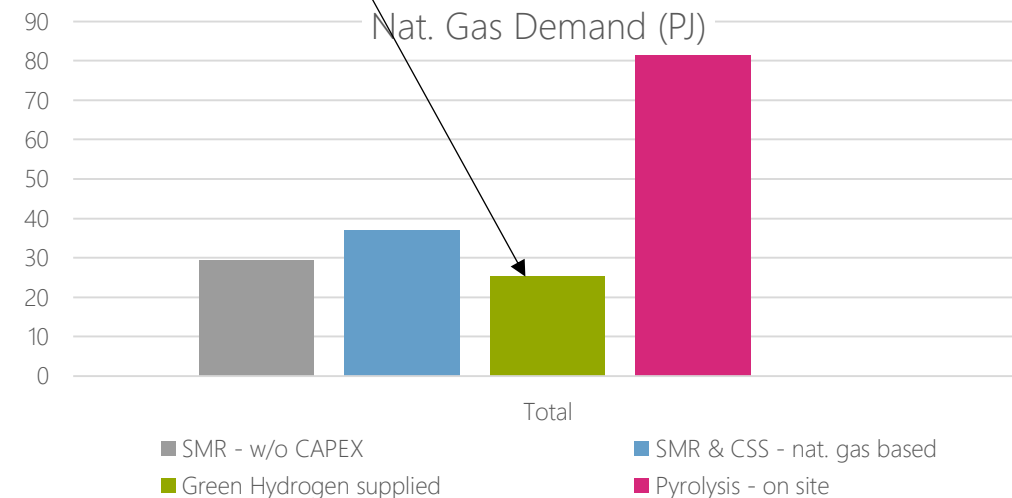
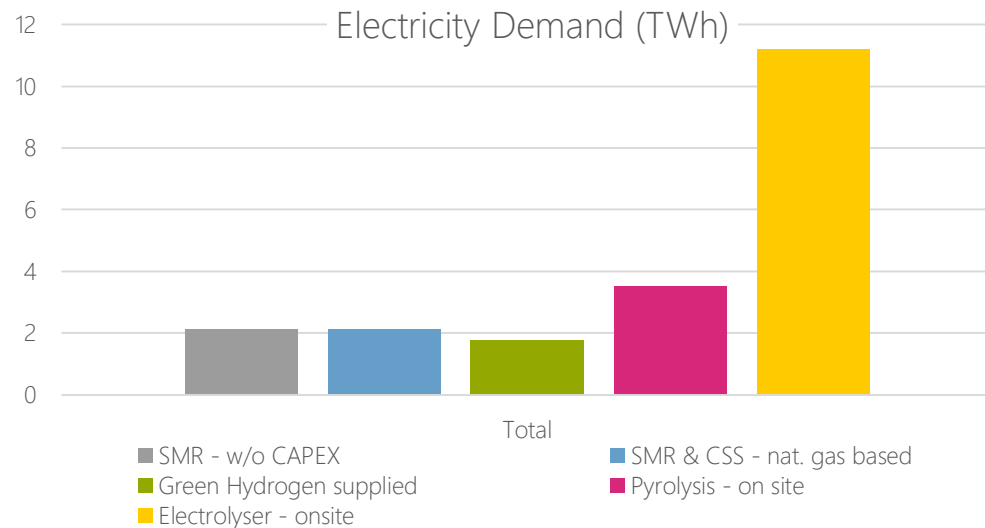

**Based on CBS data obtained from www.energiein nederland.nl, accessed April 2020

OVER TIME, CONDITIONS FOR AMMONIA SITES IN THE ARRRA REGION WILL BECOME INCREASINGLY SIMILAR

Observations

- › Currently, BE, DE and NL differ in terms of energy markets and emission intensity of electricity, but expecting integrated energy markets in near-future NWE, these factors will become more uniform over time
- › Political borders may remain, but “technical” and regulatory borders disappear
- › Given the similarities and impact of transitions of chemical sites, a cross-border approach is highly recommended

Main pathway implications for the whole region (2050)

- › **SMR (BAU):** = 2.7 Mton/a emissions, with a cumulative total of 105 Mton up to 2050
- › **SMR-CCS on-site:** + 2.7 Mton/a CO₂ pipeline and storage infrastructure capacity
- › **Pyrolysis on-site:** + 104 PJ/a natural gas supply, high uncertainty due to low TRL of technology
- › **Electrolysis off-site:** + 4.3 GW of wind farm, electrolyser peak capacity and buffers for 350 kton/a green hydrogen
- › **Electrolysis on-site:** + 16.5 TWh (1.9 GW) electricity demand, security of carbon free electricity supply in future

OVERVIEW OF SITE-SPECIFIC ASPECTS

	Antwerp (BE)	Dormagen (DE)	Geleen (NL)	comments
Conventional	Existing Production	Existing Production	Existing Production	
SMR + CCS (blue H ₂)	Harbor location advantageous for CO ₂ export via shipping	CCS currently not possible in Germany	Offshore storage potential in empty gas fields	CO ₂ -infrastructure required -> repurposing NG pipelines
Green H ₂ (pipeline or shipping)	Hydrogen pipeline but limited capacity; Harbor location with potential for direct H ₂ terminal	Hydrogen pipeline but no connection to port	Natural gas pipelines could be converted to hydrogen	Existing hydrogen infrastructure not sufficient
Electrolysis on-site	Coastal location could lead to easy access to North Sea offshore wind park,	Good grid connection (Power plant on-site, powered by natural gas)	Existing transmission network from coast to site, although far from shore	May be limited by grid capacity and large amount of green electricity (offshore?)
	6 TWh/a would require cross-border grid improvement		11 TWh/a would require grid improvement to site	
Pyrolysis of natural gas	Strong natural gas connection	Natural gas connection with 320 000 cubic meters per hour sufficient	Existing gas infrastructure insufficient	Continuous natural gas supply required

NATURAL GAS, H₂ & CO₂-SUPPLY OF CHEMPARK DORMAGEN AN EXAMPLE

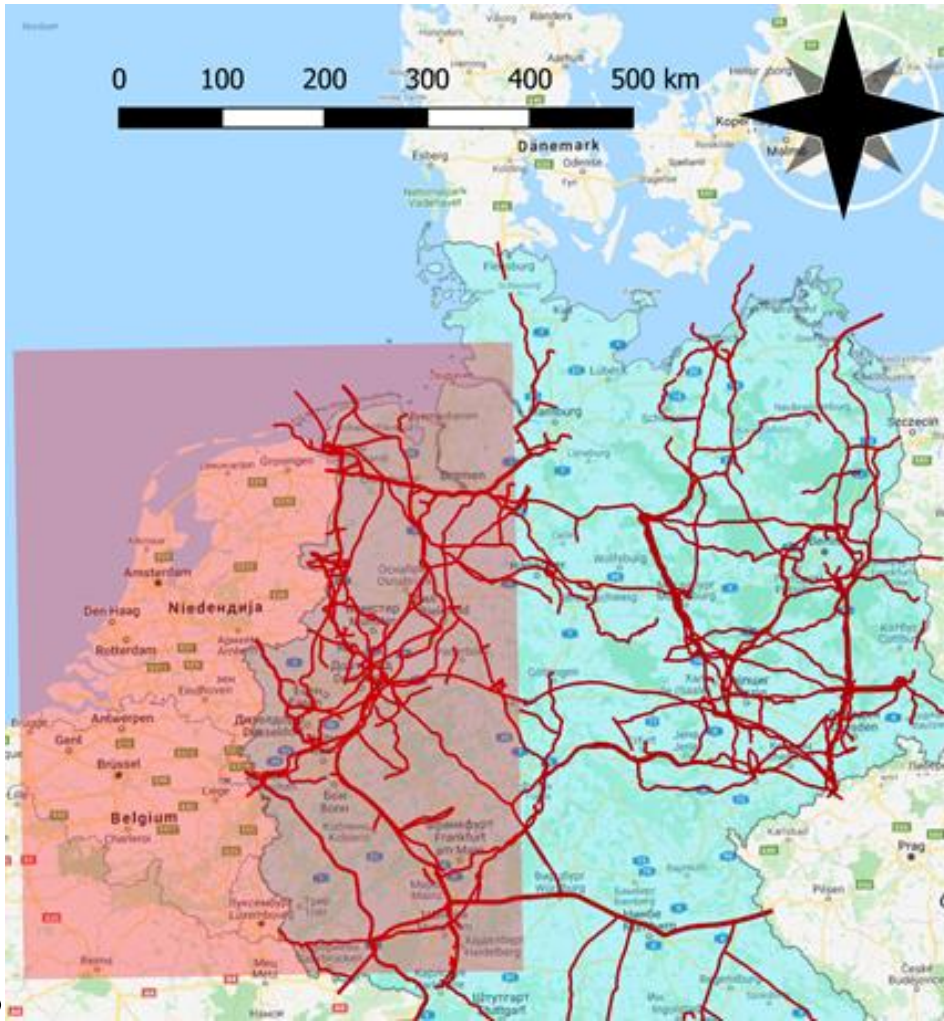

Good news:

Natural gas infrastructure capacity allows (in theory) the supply or removal of industrial sites with either natural gas or H₂ and CO₂

Dormagen	Max pressure	Diameter DN	Capacity* NG	Capacity* H ₂	Capacity** CO ₂
Pipeline 1	100 bars	1000 mm	> 1000 %	> 600 %	needed for NG
Pipeline 2	70 bars	666 mm	> 500 %	> 200 %	> 400 %

Dormagen site located in proximity to several natural gas pipelines of different capacities. Different supply scenarios seem possible.

Bad news:

The transformation pathways remain unclear and are limited considering the required uninterrupted energy supply of the sites.

* in percent of max site consumption

** in percent of SCR-CCS CO₂ output and transport of liquid at 1.5 m/s and nom. pipeline pressure

› NATURAL GAS INFRASTRUCTURE UPCOMING CHALLENGES

North-Western Europe's gas infrastructure is expected to face major challenges

Examples

- need for defossilization of energy supply
- change of (average) gas composition and need for adaption of gas applications
- fluctuating gas compositions (e.g. LNG regasification, hydrogen feed-in, methane feed-in)
- increase of entry/exit point combinations
- development of a supranational regulatory framework, certification and proof of origin processes
- change of flow directions possible for major pipelines
- business cases for future operation of underground gas storage facilities (as regulatory framework currently incentivizes building pipeline capacities rather than storage usage)
- gas demand without clear trend (e.g. increase of gas demand between 2020-2030, decrease between 2030-2050) and a discrepancy in asset lifetime (30-50 years depending on the specific asset)

› LEARNINGS / OBSERVATIONS

Main research questions:

- › What are the competitive decarbonization pathways?
- › What are the implications for the infrastructure the industrial site needs to be supplied with?
- › Which role can cross-border infrastructure play in the different scenarios?

Other take-aways

- › Chemical sites are highly interconnected in existing (fossil) energy infrastructures
- › CO₂ cost reflection in final product cost is key information to derive individual transformation pathway
- › Aiming for greenhousegas neutrality requires new infrastructure or repurposing or existing ones
- › ARRRRA-cluster is uniquely qualified due to its high integration and concentration of chemical sites
- › Infrastructure needs require strong cross-border collaboration
- › Using existing assets within the transition lowers barriers for adoption of new technologies
- › Individual solution can be developed within an integrated infrastructure in transition
- › Challenges are cross-border in nature as they follow existing and new supply and value chains

A large wind turbine is positioned on the right side of the frame, its three blades extending upwards and outwards. The background is a solid, clear blue sky. The overall image has a semi-transparent blue overlay.

TRILATERAL INFRASTRUCTURE IN THE ARRRA CLUSTER

THANK YOU VERY MUCH FOR WATCHING

TRILATERAL INFRASTRUCTURE IN THE ARRRA CLUSTER

YOU HAVE QUESTIONS?
PLEASE CONTACT US!



› APPENDIX

- › Main assumptions
- › Limitations and uncertainties
- › Assumptions on production volumes
- › Results BASF Antwerpen
- › Results Chempark Dormagen
- › Authors

› MAIN ASSUMPTIONS

	[€/tonCO ₂]	2020	2030	2040	2050	2070
CO ₂ Price		25	85	119	152	186

	[€/MWh]	2020	2030	2040	2050	2070
Grid Electricity Price w/o CO ₂ tax		45	45	45	45	45
Green Electricity Price (4.000 hrs/a)		72	62	52	42	32
Natural Gas		22.7	22.7	22.7	22.7	22.7

	Grid Elc CO ₂ intensity	2020	2030	2040	2050	2070
Belgium	[kgCO ₂ /MWh]	266	181	122	0	0
Germany	[kgCO ₂ /MWh]	478	237	76	0	0
Netherlands	[kgCO ₂ /MWh]	555	176	60	0	0

	Development electrolysis	2020	2030	2040	2050	2075
CAPEX	[€/kW]	1200	950	850	750	500
Efficiency	[%]	1	1	1	1	1
CAPEX	[€/tH ₂]	7707	5695	4931	4215	2645
CAPEX	[€/tNH ₃]	1369	1011	876	748	470
OPEX	[€/kW]	36	29	26	23	21
OPEX	[€/tH ₂]	231	171	148	126	108
Lifetime	[h]	50000	60000	70000	80000	100000

› WEO 2019 Sustain. Dev. Scenario & extrapolations

› Eurostat

› TYNDP 2020 (National Trends Scenario)

› Vito/Energyville & extrapolations

› European Environment Agency

› TYNDP 2020 (National Trends Scenario)

› <https://doi.org/10.1016/j.apenergy.2018.08.027>

*Potential of Power-to-Methane in the EU energy transition to a low carbon system using cost optimization (DVGW et al.)

› LIMITATIONS AND UNCERTAINTIES

Limitations of approach:

- Limitation on one **product** (ammonia): Results are not (fully) applicable for other products.
- Limitation on **site location**: Results are not necessarily applicable for other sites as results seem site-specific.
- Some technologies and processes currently lack **technological maturity** (e.g. methane pyrolysis) and/or **social acceptance** (e.g. CCS) which leads to significant uncertainty.

Limitations in data availability:

- Most data for chemical and industrial sites and (critical) infrastructure is **not public domain data**
- Use of **aggregated data** ...

Limitations in timeseries forecasting:

- Timeseries forecasting strongly depends on **political and regulatory actions** that we currently witness to be subject to major changes (EU Green Deal, Paris agreement and their translations in national laws)
- Especially the effects and potential business models (and hence alternatives) that arise of **high CO₂-prices** are little known and controversially discussed in literature

› ASSUMPTIONS ON PRODUCTION VOLUMES

› Links to reference for ammonia (and urea) production of individual sites

› Antwerp (BE)

<https://www.globalsyngas.org/resources/world-gasification-database/basf-antwerpen-ammonia-plant>

› Geleen (NL)

https://www.pbl.nl/sites/default/files/downloads/pbl-2019-decarbonisation-options-for-the-dutch-fertiliser-industry_3657.pdf

› Dormagen (DE)

<https://www.globalsyngas.org/resources/world-gasification-database/dormagen-ammonia-plant>

RESULTS BASF ANTWERP

- › Belgian yearly industrial electricity demand: ~38 TWh (Eurostat 2018)
- › Belgian yearly industrial gas demand: ~212 PJ (final energy & non-energy use, Eurostat 2018)
- › Blue hydrogen pathway produces 0.9 Mton CO₂ per annum that needs to be transported away from the site

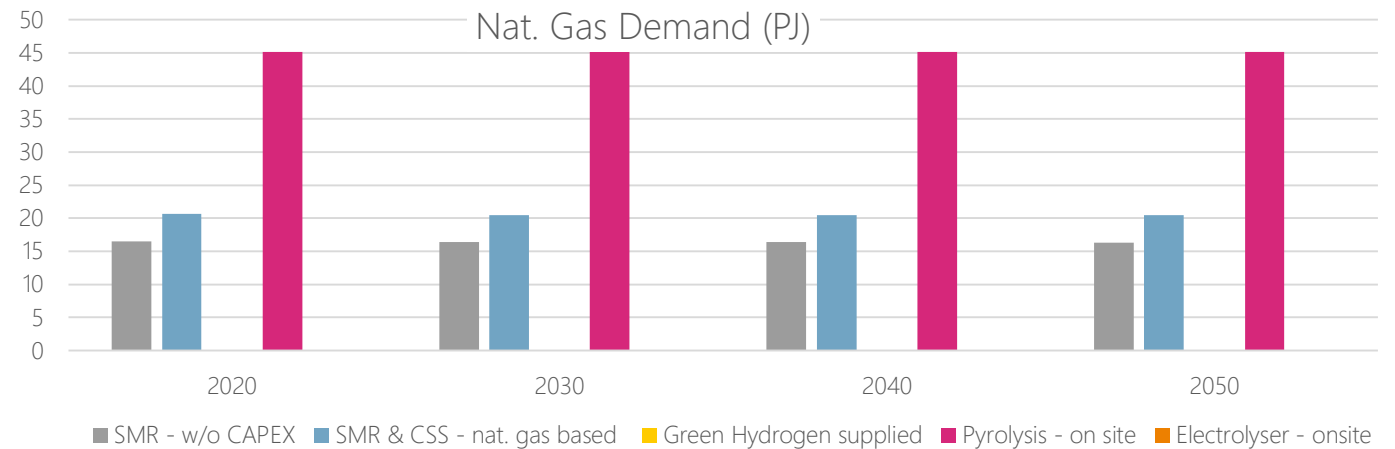
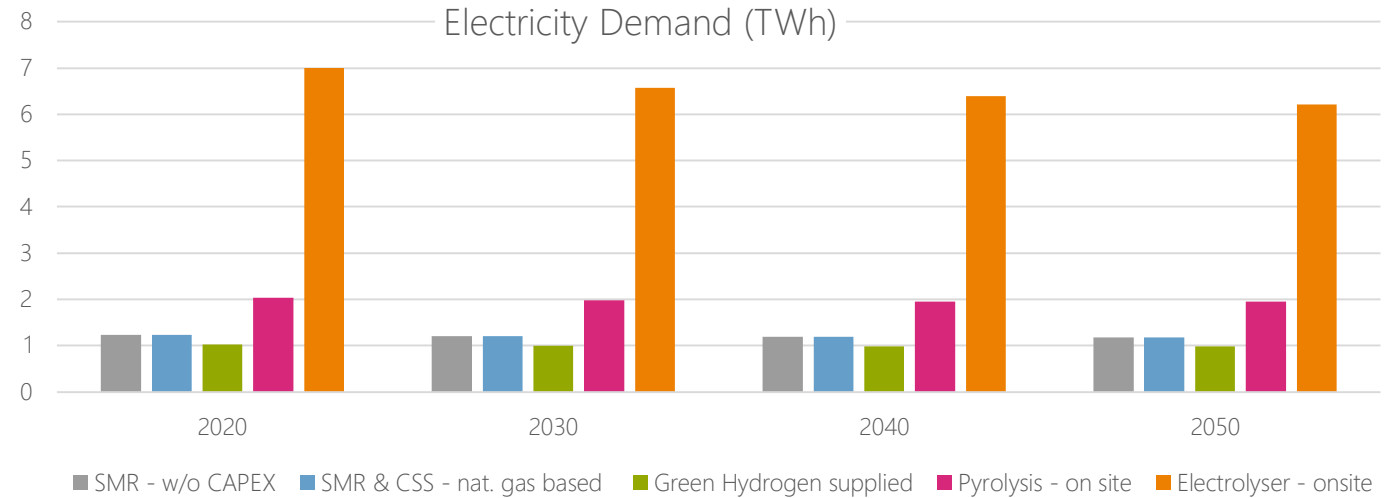

› ADDITIONAL CONTENT BELGIUM

- › 600 kt of ammonia production in Belgium (2/3 of the total) is located in the harbor of Antwerp
- › Transitioning from SMR to onsite electrolyser would have significant impact on the Belgian grid and cross-border connections: from ~1.2 to ~6 TWh/year
- › The harbor location offers unique challenges and opportunities:
- › The existing grid is highly complex and interconnected, serving one of the most dense industrial clusters in Europe.
- › Potential (green) electricity supply from future off-shore wind in the North Sea
- › Hydrogen (and other molecule) imports via shipping



RESULTS CHEMPARK DORMAGEN

- › German yearly industrial electricity demand: 226 TWh (2018, AGEB)
- › German yearly industrial gas demand: 930 PJ (2018, AGEB, industrial and non-energy)
- › Blue hydrogen pathway produces 0.5 Mton CO₂ per annum that needs to be transported away from the site

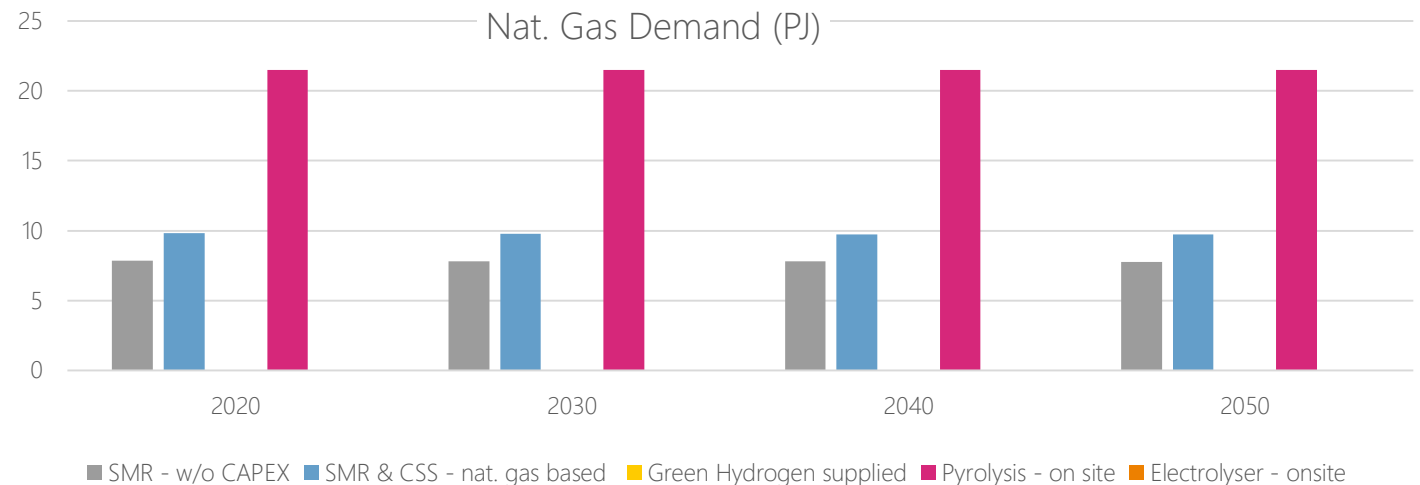
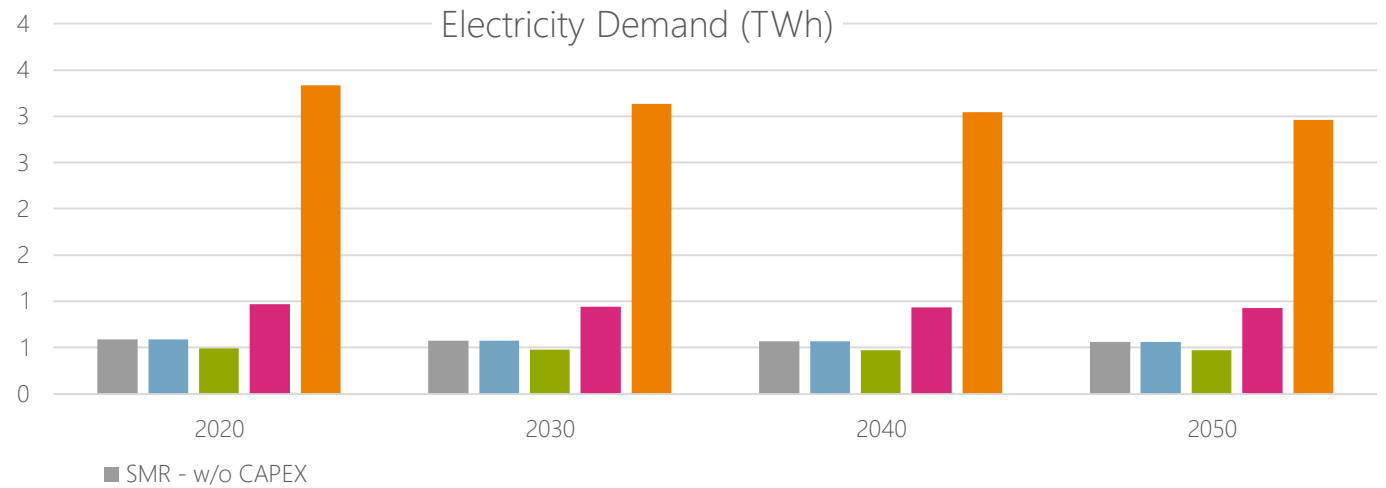

› ADDITIONAL CONTENT GERMANY

- › New processes can significantly reduce emissions almost immediately (except electrolysis with grid electricity) from 2035 on.
- › Pyrolysis and blue hydrogen are likely to become competitive against depreciated conventional production around 2050.
- › Large uncertainties due to low TRL (pyrolysis) and unknown CO₂-storage costs (blue hydrogen).
- › On-site electrolysis (grid) and green hydrogen (pipeline) remain non-competitive against depreciated conventional production within the time period considered.
- › Current energy infrastructure could accommodate pyrolysis, blue hydrogen (with CO₂ pipeline) and green hydrogen (H₂-pipeline required)
- › On-site electrolysis would require significant extension of electrical connection capacity
- › Due to late adoption of novel processes, emissions are expected to rise

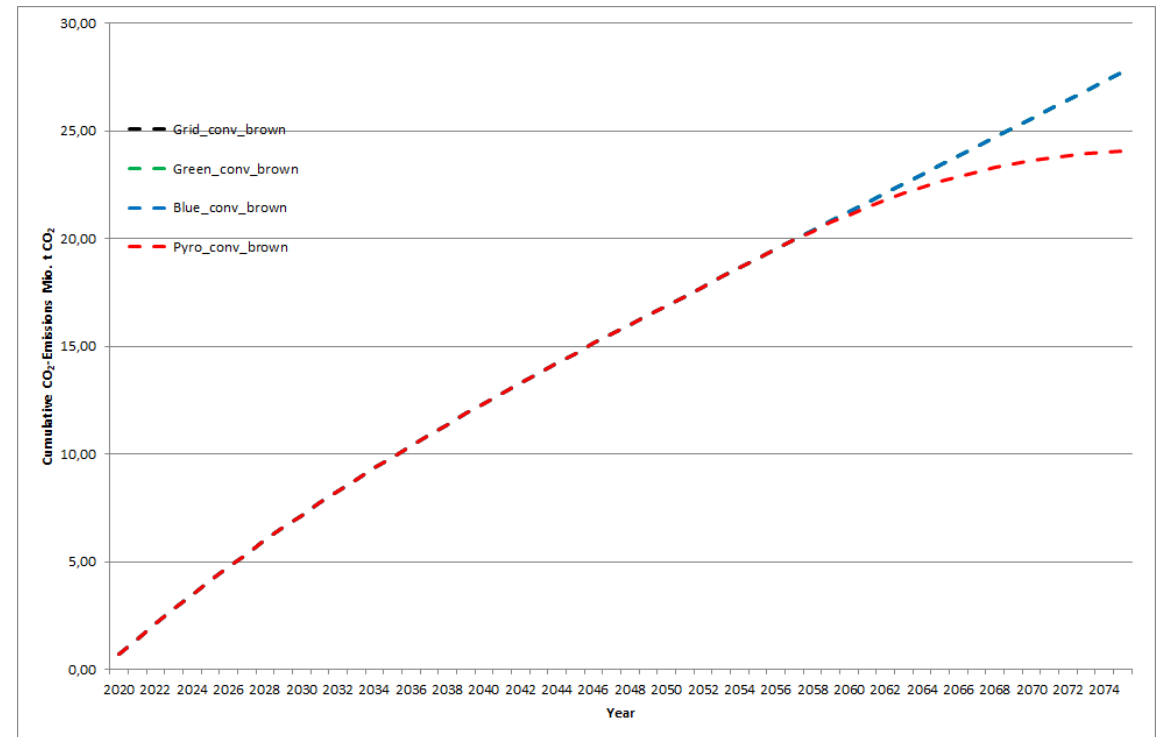

› A CLOSE LOOK ON H₂ AND CO₂-COMPATIBILITY OF GAS TRANSPORT INFRASTRUCTURE

H₂-compatibility of gas transport infrastructure

1. ... has been a research focus (as blend) and is considered a technical challenge.
2. Piping: Repurposing existing natural gas infrastructure for hydrogen transport is feasible but depends on material and pressure (H₂ embrittlement)
3. Compressor stations, valves, regulators, and metering stations need to be replaced.
4. Parallel transport infrastructures for H₂ and (renewable) methane seem more promising as transporting blends of those gases (for most applications)
5. Moisture needs to be removed (risks: corrosion)

CO₂-compatibility of gas transport infrastructure

1. ... is expected to be less of a technical challenge and ready for demonstration.
2. Piping: regular steel can be used for most applications, for supercritical operation stainless steel seems to be advisable
3. Valves & regulators: most metals can be used (copper, aluminum, steel, stainless steel, non-ferrous metals)
4. Compressor stations might need to be re-equipped depending on CO₂ transport parameters (state, pressure), lubricant needs to be approved for CO₂, e.g. ester oils.
5. Moisture and CO need to be removed (risks: corrosion and stress corrosion cracking)

› AUTHORS

Name	Organization
Ausfelder, Florian	DECHEMA
Beek, Floris van de	TNO
Bhardwaj, Rajat	TNO
Meinke-Hubeny, Frank	Vito/Energyville
Lodewijks, Pieter	Vito/Energyville
Mueller, Sabrina	DECHEMA
Perez, Diana	Vito/Energyville
Ruf, Johannes	DVGW
Rijkers, Monique	TNO